

Decks

DECK INSTALLATION GUIDELINES

Items needed:

- City of Antigo Building Permit
- **Proper Fees--\$7.00 per thousand of construction or Minimum of \$30.00**
- **Site Plan to include:**
 - Setbacks to property lines
 - Distances to other structures
 - Drainage easements
 - Utility easements
- **Deck detail**
 - Type of material – treated lumber, composite wood, etc.
 - How is it put together – blueprints or hand drawn sketch
 - Material sizes
 - Footings
 - Handrails
 - Guardrails
 - Steps
 - Support spacing
 - Attachment to house detail



Items for Consideration:

1. Drainage easements
2. Utility easements
3. Property lines
4. Diggers Hotline (1-800-242-8511)
5. Plan ahead for future (fences, additions, sheds, etc.)



ANSWERS TO SOME BASIC DECK QUESTIONS

Items required for permit:

Plot Plan - location on property with distances to property lines

Deck Detail - to include post spacing, joist sizes, and type of lumber

Permit Fee and Application

Must meet requirements of COMM 21.225

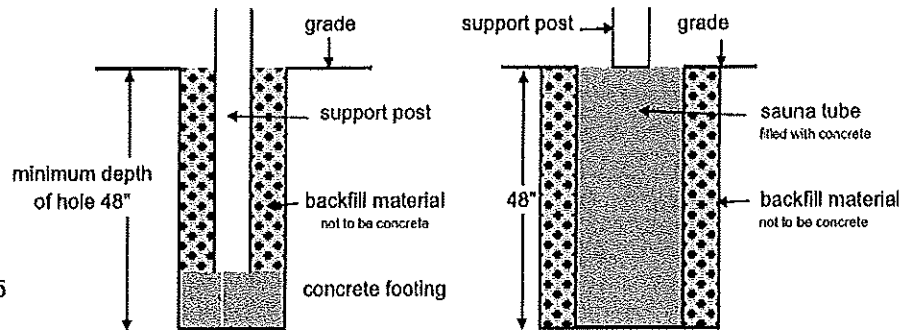

Footing and frost protection COMM 21.15 and 21.16

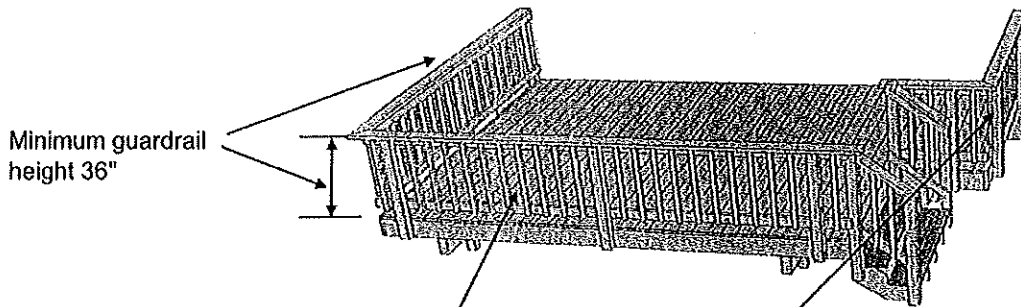

CODE CHANGE EFFECTIVE JANUARY 1, 2005

Maximum spacing of guardrail system never to exceed 4" sphere**
 **This 4" limitation will also apply to open risers.

Grippable handrail COMM 21.04 (30" - 38" above nose of tread)

Steps - riser height must be uniform and not exceed 8"

Tread depth must be uniform minimum 9" measured from nose to nose

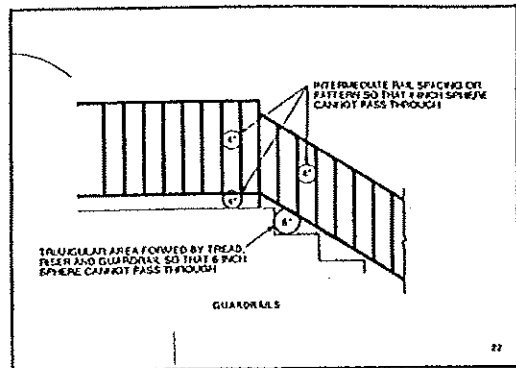
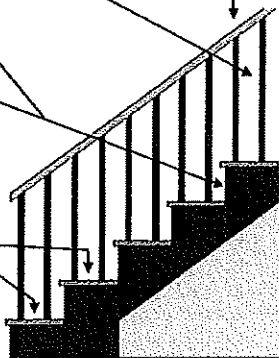

21.04(2)(a)5. HANDRAIL SHAPES

ROUND

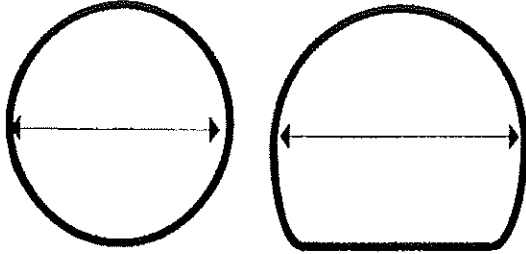

← **MAXIMUM 2"** →
DIAMETER

RECTANGULAR

OK (w x ht):
1/2"x 2-5/8"
3/4"x 2-1/2"
1"x 2-3/8"
1-1/8"x 2-5/16"
1-1/2"x 2-1/8"
1-7/8"x 1-15/16"
← →

OK (w x ht):
2"x 1-7/8"
2-1/2"x 1-5/8"
← 2-3/4"x 1-1/2" →
2-7/8"x 1/2" TO 1-7/16"

← **MAXIMUM 2-7/8"** →
CROSS SECTION
MAX. 6-1/4"
GRIPPING
SURFACE INCL.
MIN. 1/4"
RECESS ON
EACH SIDE

OTHERS

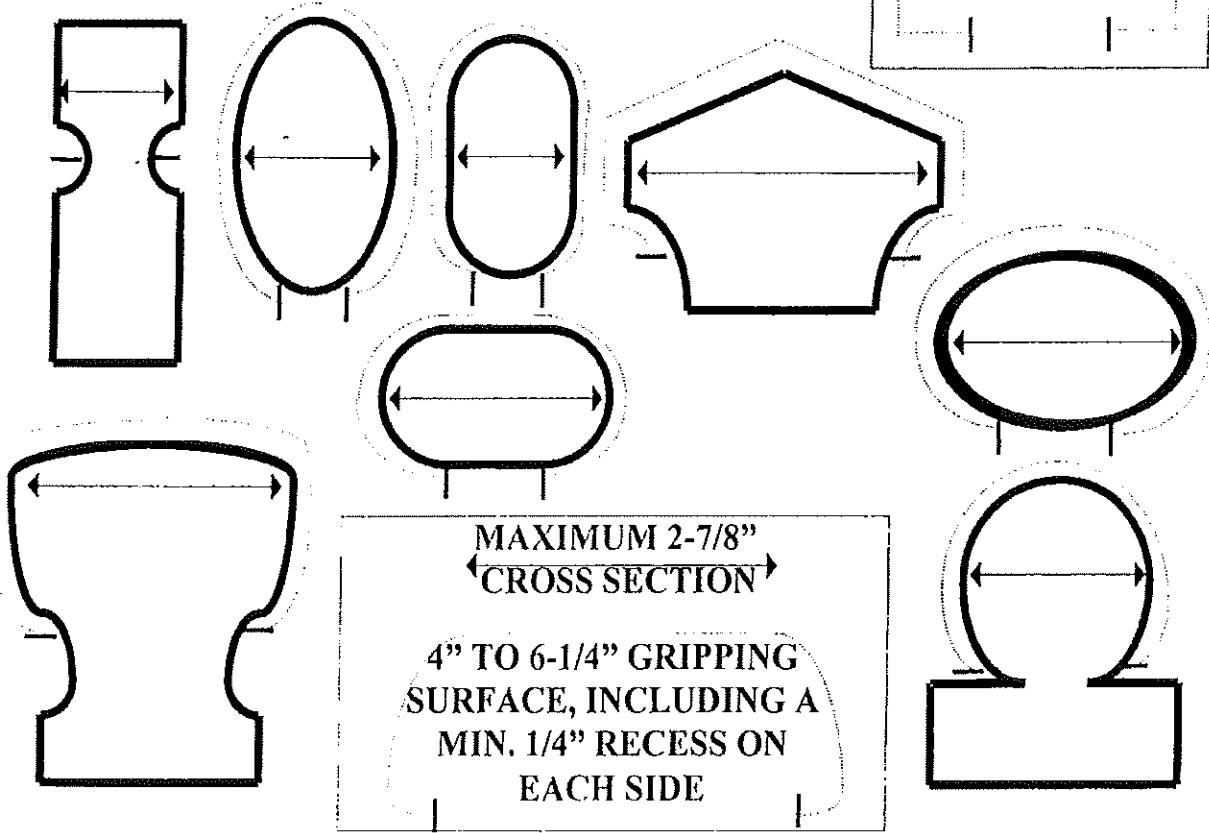

← **MAXIMUM 2-7/8"** →
CROSS SECTION
4" TO 6-1/4" GRIPPING
SURFACE, INCLUDING A
MIN. 1/4" RECESS ON
EACH SIDE